

MODEL 22VB

3-Phase Voltage Band Monitor with Adjustable Trip & Restart Delays

- Monitors for Phase Loss, Phase Reversal, Over/Under Voltage and Voltage Unbalance
- Universal Voltage Range 190-480VAC, 50/60Hz
- Adjustable Trip and Restart Delays
- 2 SPDT Relay Outputs
- Surface Mount

DESCRIPTION

The Model 22VB is a microcontroller-based universal 3-phase voltage band monitor for protecting 3-phase motors of any size from abnormal power conditions. The Model 22VB can detect under voltage, over voltage, voltage unbalance, reverse phase, and single-phasing even when regenerated voltage is present. Status of the 3-phase system is indicated by LEDs .

Relay operation is fail-safe, i.e. the two SPDT output contacts drop out when a fault condition or loss of power occurs. Under and over voltage trip points are both adjustable. The under voltage adjustment has two scales, 185-240VAC and 370-480VAC. The over voltage adjustment also has two scales, 208-264VAC and 416-528VAC. The Model 22VB will auto-range to the appropriate scale. A trip delay adjustment for preventing nuisance tripping during power fluctuations and a restart delay adjustment for preventing short cycling in compressor applications have also been provided. Voltage unbalance trip point is fixed at 6%.

The Model 22VB does not require a neutral connection and can be used on either Wye or Delta systems. Operating power for the Model 22VB is drawn from phases A and C.

DIMENSIONS

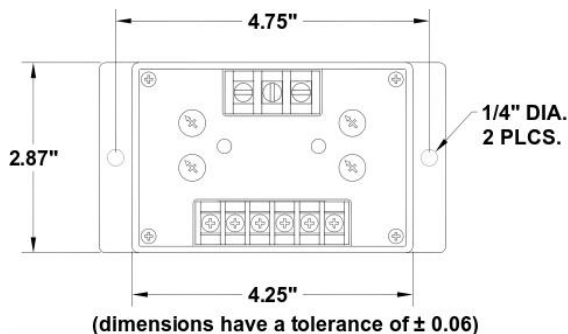

SPECIFICATIONS

Model	22VB
Operating Voltage	190-480 VAC
Frequency	50/60Hz
Type of Measurement	RMS
Auto Ranges	Yes
Under Voltage Trip Reset	185-480VAC Trip setting +3%
Over Voltage Trip Reset	208-528VAC Trip setting -3%
Voltage Unbalance Trip Reset	(conforms to NEMA) 6%, Fixed 5% Fixed
Trip Delay Time Over, Under, & Unbalanced Single-Phasing Faults Unbalance > 15%	1-30 sec., adjustable 1 sec., fixed 1 sec., fixed
Restart Delay	1-500 sec., adjustable
Reset	Automatic
Output Contacts	2X SPDT 10A at 240VAC resistive
Power Consumption	6W at 480VAC
Operating Temp	- 20° to +140° F
Humidity Tolerance	0-97% w/o condensation
Terminal Torque	9 in lbs max for power and relay terminals 4.4 in lbs max for manual reset terminals
Wire Type	12-22 AWG for power and relay terminals 12-30 AWG for manual reset terminals
Enclosure	NORYL plastic
Mounting	DIN Rail or Surface Mount
Weight	12.5 oz.
Low Current Options	Models ordered with suffix "SG" have silver with gold flash contacts

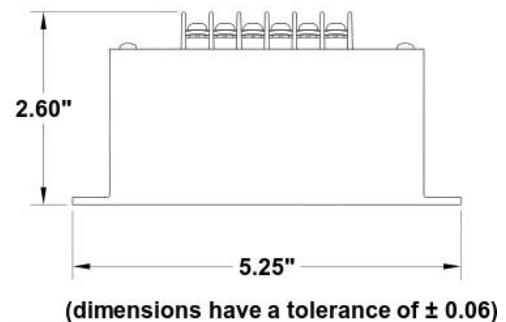

Telephone: Main - (918) 438-1220
Sales - (800) 862-2875
Fax: (918) 437-7584
E-mail: sales@time-mark.com
Internet: http://www.time-mark.com



11440 East Pine Street
Tulsa, Oklahoma 74116

04/2019
© 2019 TIME MARK CORPORATION

TIME MARK is a division of  AEMT, Inc.

MODEL 22VB Universal 3-Phase Monitor

READ ALL INSTRUCTIONS BEFORE INSTALLING, OPERATING OR SERVICING THIS DEVICE.
KEEP THIS DATA SHEET FOR FUTURE REFERENCE.

GENERAL SAFETY

POTENTIALLY HAZARDOUS VOLTAGES ARE PRESENT AT THE TERMINALS OF THE MODEL 22VB.
ALL ELECTRICAL POWER SHOULD BE REMOVED WHEN CONNECTING OR DISCONNECTING WIRING.
THIS DEVICE SHOULD BE INSTALLED AND SERVICED BY QUALIFIED PERSONNEL.

Installation Instructions

INSTALLATION

Mount the Model 22VB to the back panel of a suitable enclosure using 1/4" hardware (Mounting hardware is not included).

Connect terminals A, B, and C to the line side of the motor starter. Connect the output relays to the control circuit.

TYPICAL APPLICATION MOTOR PROTECTION

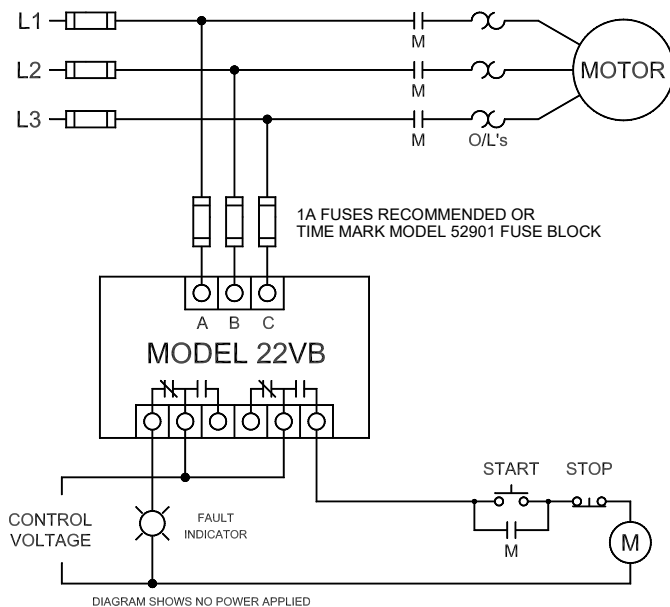

OPERATION (Cont'd)

The status of the 3-phase system is indicated by the red and green LEDs as follows:

The relay contacts will transfer after applying correct voltage and phase rotation for the length of the restart delay. The green LED will blink during the restart delay and will then remain on indicating the relay contacts have transferred.

LED STATUS

UNDER	ON CONTINUOUSLY	RED
OVER		
UNBAL / SINGLE PH		
REVERSE PHASE		
RUN	ON CONTINUOUSLY	GRN
RESTART DELAY		

TROUBLESHOOTING

Should the Model 22VB Monitor fail to operate properly, check that all three voltages are present, and are of the correct voltage level and phase rotation (a Model 108A or 108B Phase Sequence Detector should be used to verify phase rotation). Check all fuses and verify that all wiring connections are correct. If problems persist, contact your local Time Mark Distributor, or the factory for assistance (Monday-Friday, 8 a.m. to 5 p.m. CST).

WARRANTY

This product is warranted to be free from defects in materials and workmanship, and is covered by our exclusive **5-year Unconditional Warranty**. Should this device fail to operate for any reason, we will repair it for five years from the date of manufacture. For complete warranty details, see the *Terms and Conditions of Sales* page in the front section of the Time Mark catalog or contact Time Mark at 1-800-862-2875.

OPERATION

Set the OVER and UNDER voltage adjustments to the trip points required for the application. Set the RESTART and TRIP delay adjustments as required for the application.

Telephone: Main - (918) 438-1220
Sales - (800) 862-2875
Fax: (918) 437-7584
E-mail: sales@time-mark.com
Internet: http://www.time-mark.com



11440 East Pine Street
Tulsa, Oklahoma 74116
04/2019
© 2019 TIME MARK CORPORATION
TIME MARK is a division of AEMT, Inc.