

MODEL 19

3-Phase Monitor with Trip & Restart Delays

- Detects phase loss, low voltage, phase reversal
- 50Hz, 60Hz and 400Hz models
- Automatic reset
- UL Recognized in the U.S. and Canada
- Five year unconditional warranty

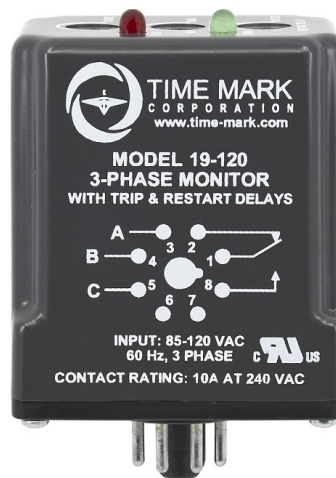

DESCRIPTION

The **Model 19** continuously monitors 3-phase power lines for abnormal conditions. When properly adjusted, the Model 19 monitor will detect phase loss on a loaded motor even when regenerated voltage is present.

This device consists of a microcontroller with a voltage and phase-angle sensing circuit, driving an electromechanical relay. When correct voltage and phase rotation are applied, the internal relay will energize. A fault condition will de-energize the relay. When the fault is corrected, the monitor will automatically reset. An adjustable restart delay prevents short cycling in compressor applications and an adjustable trip delay prevents nuisance tripping during power fluctuations.

The Model 19 does not require a neutral connection and can be used with Wye or Delta systems. Voltage ranges are sufficiently wide to allow for proper adjustment to existing conditions. Both "FAULT" and "NORM" condition indicators are provided to aid in adjustment and system trouble-shooting.

All versions of the Model 19 are available with optional gold flashed silver contacts for low current applications.

SPECIFICATIONS

Model	19-120	19-208/240	19-480	19-380 -50Hz	19-120 -400Hz	19-208/240 -400Hz	19-415 -50Hz	19-480 -400Hz
Nominal AC (phase to phase)	120VAC	208/240VAC	480VAC	380VAC	120VAC	208/240VAC	415VAC	480VAC
Adjustment range	85 to 120VAC	160 to 240VAC	380 to 480VAC	300 to 400VAC	85 to 120VAC	160 to 240VAC	340 to 440VAC	380 to 480VAC
Frequency	60Hz	60Hz	60Hz	50Hz	400Hz	400Hz	50Hz	400Hz
Power consumption	1.4W	2.4W	3.7W	3.0W	1.4W	2.4W	3.3W	3.7W
Transient protection	2500VAC for 10ms							
Repeat accuracy	± 0.1% of set point (fixed conditions)							
Trip delay	1-30 sec.							
Restart Delay	1-300 sec.							
Dead band	Approximately 2%							
Output contacts	SPDT 10 amps at 240VAC resistive (Low current options available for all models—See below)*							
Expected relay life	Mechanical: 10 million operations Electrical: 100,000 operations at rated load							
Operating temp	-20° to +131° F							
Humidity tolerance	0 - 97% w/o condensation							
Enclosure material	NORYL plastic cover; 6/6 Nylon base							
Mounting	8-pin socket (**sold separately)							
Weight	4.5 ounces							
* Low Current Options	For low current applications: Models ordered with suffix "/SG" will have silver with gold flash contacts (SPDT 5 amps at 120VAC resistive)							
Agency Approval	UL Recognized (U.S. and Canada for use in a Pollution Degree 2 Environment)						NONE	

** Order 8-pin socket number 51X120

TYPICAL APPLICATION

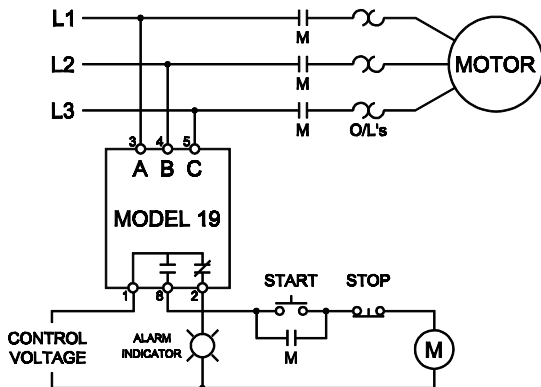

DIMENSIONS

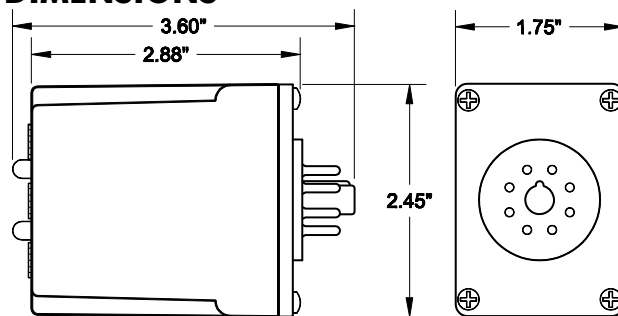

(dimensions have a tolerance of ± 0.06)

Telephone: Main - (918) 438-1220
Sales - (800) 862-2875
Fax: (918) 437-7584

E-mail: sales@time-mark.com
Internet: http://www.time-mark.com



TIME MARK
CORPORATION

11440 East Pine Street
Tulsa, Oklahoma 74116

10/2021
© 2021 TIME MARK CORPORATION

MODEL 19

3-Phase Monitor

READ ALL INSTRUCTIONS BEFORE INSTALLING, OPERATING OR SERVICING THIS DEVICE.
KEEP THIS DATA SHEET FOR FUTURE REFERENCE.

GENERAL SAFETY

POTENTIALLY HAZARDOUS VOLTAGES ARE PRESENT AT THE TERMINALS OF THE MODEL 19.
ALL ELECTRICAL POWER SHOULD BE REMOVED WHEN CONNECTING OR DISCONNECTING WIRING.
THIS DEVICE SHOULD BE INSTALLED AND SERVICED BY QUALIFIED PERSONNEL.

Installation Instructions

WARNING

IN APPLICATIONS WHERE VOLTAGES IN EXCESS OF 300VAC ARE TO BE MONITORED, BE CERTAIN TO USE THE TIME MARK MODEL 51X120 8-PIN SOCKET, OR AN EQUIVALENT HIGH QUALITY 600VAC RATED SOCKET.

INSTALLATION

Mount the 8-pin socket in a suitable enclosure. A NEMA-1 rated enclosure, designed for socket-mounted relays is available from Time Mark Corporation.

Connect 3-phase power to terminals 3, 4, and 5 on the socket. Phase rotation should be verified using a Time Mark Model 188 Phase Sequence Detector.

Connect the load control wiring to the appropriate terminals on the socket:

For motor control applications; use terminals 1 and 8.

For phase loss alarm applications; use terminals 1 and 2.

Insert the Model 19 into the socket and apply power. If the contact does not transfer (green light ON), check that all phases are present, and of the correct voltage. If power is correct, rotate the trip adjust control counter-clockwise.

If the contact still does not transfer, remove power and reverse two of the three phase wires at the socket (*phase rotation is reversed*). Re-apply power. The contact should transfer to provide a signal path between pins 1 and 8.

NOTE: When installing the Model 19 monitor in areas of high humidity or contamination, it is recommended that the base area and all exposed metal parts of the socket be coated liberally with a good quality silicone grease, such as Dow Corning DC-4 or DC-4X. Insert the unit into the socket and wipe off excess grease around the base. This will prevent the entrance of moisture and other contaminants into the base and socket areas.

ADJUSTMENT SETTINGS

The following procedure will allow the Model 19 to be adjusted to achieve a trip point just below the nominal phase-to-phase voltage, where the unit is applied:

Initially, set all adjustments fully counterclockwise.

Rotate the trip adjust control clockwise until the red (FAULT) indicator illuminates.

ADJUSTMENT SETTINGS (cont'd)

Next, slowly rotate the trip adjust control in a counter-clockwise direction, until the green (NORM) indicator illuminates.

At this point, the Model 19 is the most sensitive to irregular power line conditions. Adjust the trip delay as required to prevent nuisance tripping due to power fluctuations or motor start-ups. Adjust the restart delay as required for the application.

A more accurate setting will require the use of a 3-phase variac to lower the voltage to an exact measurable setting. Time Mark also offers a factory set version of all models and voltage ranges, for only a small additional charge.

PIN DIAGRAM

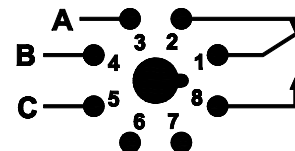

TROUBLESHOOTING

Should the Model 19 Monitor fail to operate properly, check that all three voltages are present, and are of the correct voltage level and phase rotation (a Model 188 Phase Sequence Detector should be used to verify phase rotation). Check all fuses and verify that all wiring connections are correct. If problems persist, contact your local Time Mark Distributor, or the factory for assistance (*Monday-Friday, 8 a.m. to 5 p.m. CST*).

WARRANTY

This product is warranted to be free from defects in materials and workmanship, and is covered by our exclusive **5-year Unconditional Warranty**. Should this device fail to operate for any reason, we will repair it for five years from the date of manufacture. For complete warranty details, see the *Terms and Conditions of Sales* page in the front section of the Time Mark catalog or contact Time Mark at 1-800-862-2875.

Telephone: Main - (918) 438-1220

Sales - (800) 862-2875

Fax: (918) 437-7584

E-mail: sales@time-mark.com

Internet: http://www.time-mark.com



TIME MARK
CORPORATION

11440 East Pine Street
Tulsa, Oklahoma 74116

10/2021
© 2021 TIME MARK CORPORATION