

MODEL 263

3-Phase Monitor

- Detects Phase Loss or Reversal and Low Voltage
- 400Hz and Gold Contact Options
- Automatic or Manual Reset
- UL Recognized and CSA Certified



DESCRIPTION

The **Model 263** continuously monitors 3-phase power systems for phase loss, low voltage and phase reversal. The monitor consists of a solid-state sensing circuit, driving an electromechanical relay.

Applying correct voltage and phase rotation energizes the relay. When properly adjusted, a fault condition will cause the relay to de-energize, even when regenerated voltage is present.

When the fault is corrected, the Model 263 automatically resets. A manual reset version is also available. The SG Model has silver with gold flash contacts for low current applications.

The Model 263 does not require a neutral connection, and can be used on Wye or Delta systems. Each of the five different voltage ranges is adjustable to allow the monitor to be set for existing conditions. NORMAL and TRIP LED indicators are provided to aid in adjustment and system troubleshooting.

SPECIFICATIONS

AUTO Reset	A263	B263	C263	D263	EX263
MANUAL Reset	A263M	B263M	C263M	D263M	EX263M
GOLD-AUTO Reset	A263SG	B263SG	C263SG	D263SG	EX263SG
GOLD-MAN Reset	A263SGM	B263SGM	C263SGM	D263SGM	EX263SGM
Nominal AC voltage (phase to phase)	120VAC	208/240VAC	480VAC	575VAC	380VAC
Adjustment Range	85-120V	160-240V	380-480V	450-575V	300-400V
Frequency	60Hz	60Hz	60Hz	60Hz	50Hz
Power Consumption	0.75W	1.5W	4.5W	7.5W	4.5W
Transient Protection	2500 VRMS for 10ms				
Repeat Accuracy	± 0.1% of setpoint (fixed conditions)				
Response Time	50ms				
Dead Band	Approximately 2%				
Output Contacts	All SG models: SPDT silver w/gold flash 5 amps at 240VAC resistive All other models: SPDT 10 amps at 240VAC resistive				
Expected Relay Life	Mech: 10 million operations Elec: 100,000 operations at rated load				
Operating Temp	- 20° to +131° F				
Humidity Tolerance	0 - 97% w/o condensation				
Enclosure Material	ABS plastic				
Mounting	surface				
Weight	9.5 oz				
Agency Approvals	ALL VERSIONS - UL Recognized and CSA Certified				

DIMENSIONS

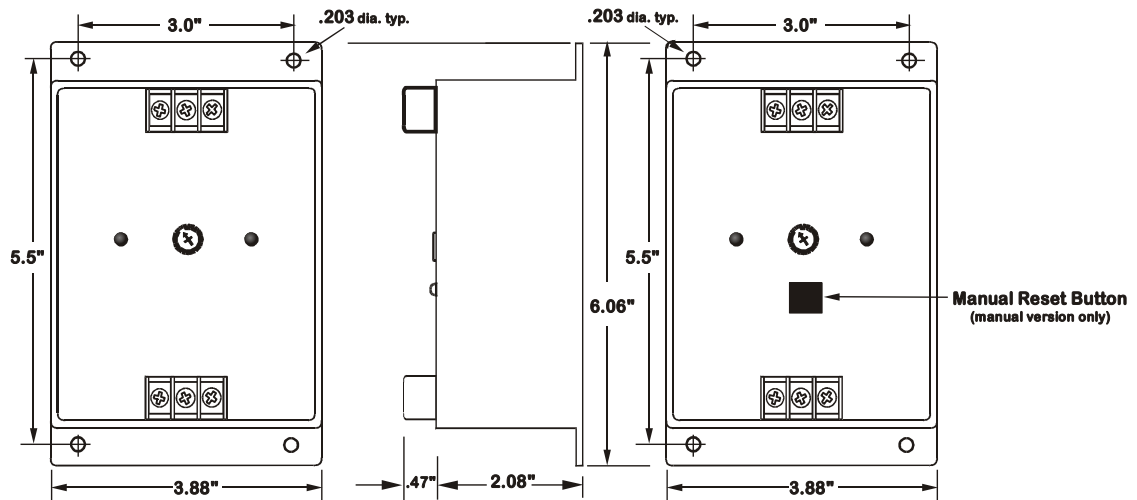

Telephone: Main - (918) 438-1220
Sales - (800) 862-2875
Fax: (918) 437-7584

E-mail: sales@time-mark.com
Internet: http://www.time-mark.com



TIME MARK
CORPORATION

11440 East Pine Street
Tulsa, Oklahoma 74116

11/2011
© 2011 TIME MARK CORPORATION

TIME MARK is a division of  AEMT, Inc.

MODEL 263 3-Phase Monitor

READ ALL INSTRUCTIONS BEFORE INSTALLING, OPERATING OR SERVICING THIS DEVICE.
KEEP THIS DATA SHEET FOR FUTURE REFERENCE.

GENERAL SAFETY

POTENTIALLY HAZARDOUS VOLTAGES ARE PRESENT AT THE TERMINALS OF THE MODEL 263.
ALL ELECTRICAL POWER SHOULD BE REMOVED WHEN CONNECTING OR DISCONNECTING WIRING.
THIS DEVICE SHOULD BE INSTALLED AND SERVICED BY QUALIFIED PERSONNEL.

Installation Instructions

INSTALLATION

Connect the 3-phase wires to the terminals marked **A**, **B** and **C**.

The control wiring will be connected to the opposite end of the unit, to the terminals with the contact markings. Markings on the unit are the failed condition of the contacts.

AUTOMATIC RESET VERSIONS:

Apply power. If the contacts do not transfer (TRIP LED-Off), check that all three phases are present and of the correct voltage.

If all phases are correct, rotate the VOLTS adjustment potentiometer counter-clockwise, to the low position.

If the contacts still do not transfer, remove power from the unit. Reverse any two of the three input wires and re-apply power. The contacts should transfer to the energized condition; N.O. contact-closed, NORMAL LED-On.

MANUAL RESET VERSIONS:

Apply power and press the RESET button. If the contacts do not transfer (TRIP LED-Off), check that all three phases are present and of the correct voltage.

If all phases are correct, rotate the VOLTS adjustment potentiometer counter-clockwise, to the low position and press the RESET button.

If the contacts still do not transfer, remove power from the unit. Reverse any two of the three input wires and re-apply power. Press the RESET button. The contacts should then transfer to the energized condition; N.O. contact-closed, NORMAL LED-On.

TYPICAL APPLICATION

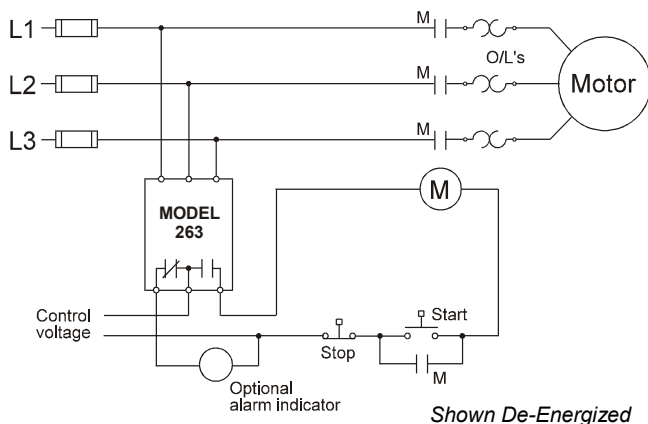

ADJUSTMENT SETTINGS

NOTE: During adjustment, you may wish to install a jumper across the control contacts, to prevent cycling the load on and off.

AUTOMATIC RESET VERSIONS:

Rotate the VOLTS adjustment slowly clockwise, until the contacts transfer to the failed condition (TRIP LED-On).

Slowly turn the adjustment back counter-clockwise, until the contacts reset to the normal condition (TRIP LED-Off).

Remove the jumper, if installed. This setting will be correct for most applications.

If nuisance tripping occurs, turn the adjustment slightly farther counter-clockwise. In adjustments to eliminate nuisance tripping, the VOLTS adjustment should be rotated in very small increments, until the true nuisance trips are eliminated.

MANUAL RESET VERSIONS:

During adjustment, you will need to press and hold the RESET button.

Rotate the VOLTS adjustment slowly clockwise, until the contacts transfer to the failed condition (TRIP LED-On). A slight buzz in the contacts may occur when the relay is at the transfer point to the failed condition. This is normal and will not occur in operation.

Slowly turn the VOLTS adjustment back counter-clockwise, until the contacts reset to the normal condition (NORMAL LED-On).

Release the RESET button, and remove the jumper, if installed. This setting will be correct for most applications.

If nuisance tripping occurs, turn the adjustment slightly farther counter-clockwise. In adjustments to eliminate nuisance tripping, the VOLTS adjustment should be rotated in very small increments, until the true nuisance trips are eliminated.

WARRANTY

This product is warranted to be free from defects in materials and workmanship, and is covered by our exclusive **5-year Unconditional Warranty**. Should this device fail to operate for any reason, we will repair it for five years from the date of manufacture. For complete warranty details, see the *Terms and Conditions of Sales* page in the front section of the Time Mark catalog or contact Time Mark at 1-800-862-2875.

Telephone: Main - (918) 438-1220

Sales - (800) 862-2875

Fax: (918) 437-7584

E-mail: sales@time-mark.com

Internet: http://www.time-mark.com



TIME MARK
CORPORATION

11440 East Pine Street
Tulsa, Oklahoma 74116

11/2011

© 2011 TIME MARK CORPORATION

TIME MARK is a division of  AEMT, Inc.