

# MODEL 421

## Over/Under Motor Load Monitor

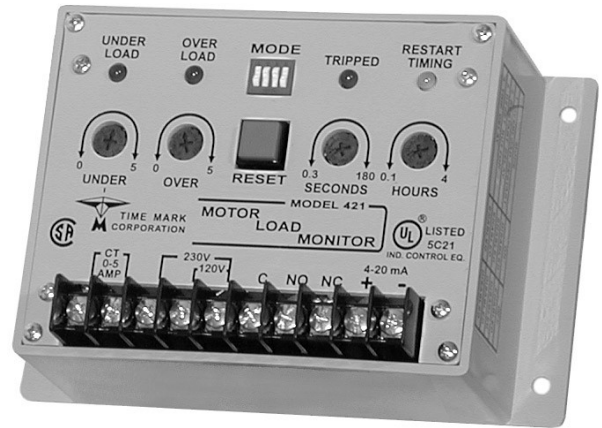

- Monitors True Motor Power (volts  $\times$  current  $\times$  power factor)
- Detects Motor Overload or Underload
- Operates on 120 or 240VAC, Single-phase or 3-phase
- Built-in Trip and Restart Delay Options



### DESCRIPTION

The **Model 421 Over/Under Motor Load Monitor** detects an overload or underload condition on all types of running motors: conveyer motors, elevator motors, mixer motors, submersible pumps, etc.

This Monitor detects the actual power used (voltage  $\times$  current  $\times$  power factor) and is more sensitive than simple current monitors. The 421 can be used with single phase motors or, using the **Model 276C** current transducer, with three-phase motors. Matching CT's allow the Model 421 to be used with most motor sizes.

Optional trip and restart delays are provided.

### TYPICAL APPLICATION -single-phase monitoring

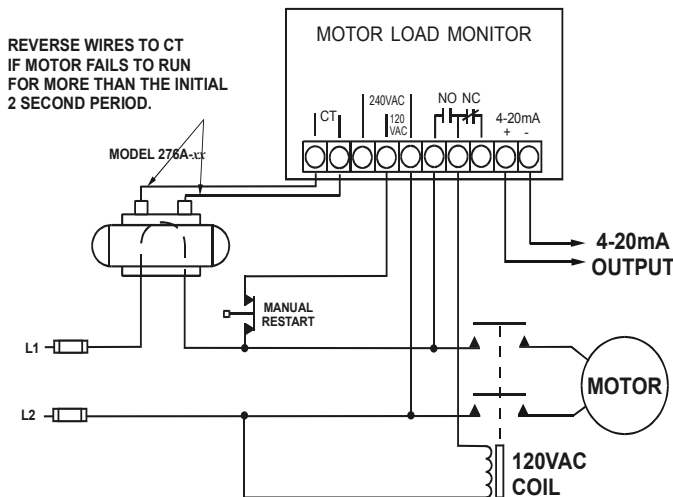

### SPECIFICATIONS

Model	421
Input Voltage Range	100-130VAC or 200-250VAC
Frequency	50/60Hz
Power Consumption	0.5 VA max.
Nominal Current	2.5 amps
Minimum Current	0.25 amps
Current Adjustment	0 - 5 amps $\times$ PF
Current Output	4-20mA for chart recorders
Repeat Accuracy	1 % (fixed conditions)
Output	SPDT 10A at 240VAC resistive
Expected Relay Life	Mech: 10 million operations Elec: 100,000 operations at rated load
Trip Delay	OFF or 0.3 to 180 seconds
Restart Delay	OFF or 0.1 to 4 hours
Indicators	Red LED: Overload or Underload; tripped Yellow LED: Restart timing
Transient Protection	2500V for 10ms
Operating Temp	- 20° to 131° F
Humidity Tolerance	97% w/o condensation
Enclosure Material	ABS plastic
Weight	1 lb.
Agency Approvals	UL Listed to US and Canadian safety standards CSA Certified

### DIMENSIONS

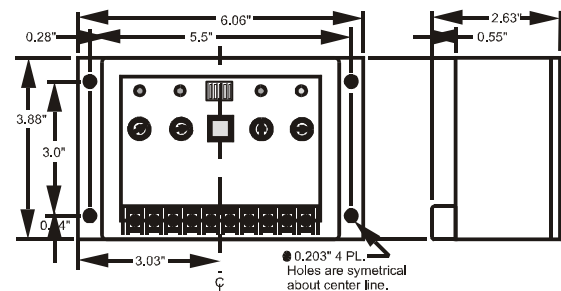

Telephone: Main - (918) 438-1220

Sales - (800) 862-2875

Fax: (918) 437-7584

E-mail: sales@time-mark.com

Internet: http://www.time-mark.com



**TIME MARK**  
CORPORATION

11440 East Pine Street  
Tulsa, Oklahoma 74116

Page 1 of 8 11/2011  
© 2011 TIME MARK CORPORATION

TIME MARK is a division of AEMT, Inc.

# MODEL 421 Over/Under Motor Load Monitor

READ ALL INSTRUCTIONS BEFORE INSTALLING, OPERATING OR SERVICING THIS DEVICE.  
KEEP THIS DATA SHEET FOR FUTURE REFERENCE.

## APPLICATION GUIDE

### GENERAL

This application guide is written for equipment designers, maintenance personnel, electrical contractors, etc.

It is intended to aid in the installation of the **Model 421 Motor Load Monitor** into motor protection systems. The notes and diagrams deal with methods of protecting motors in the event of an **underload** condition or an **overload** condition.

### THEORY

The need for a system to detect an underload condition other than by the simple monitoring of current becomes clear when examining the following waveforms.

In a purely resistive circuit, as in *Figure 1*, the current (amps) is directly proportional to the power (watts) being consumed. To find the power, multiply the voltage across the load times the current through the load. The result is in watts ( $V \times A = W$ ).

In *Figure 2*, When the load is not resistive, but inductive as it is with a motor, the formula is no longer correct. The inaccuracy occurs because the current and the voltage waveforms are not in phase.

The current waveform lags the voltage waveform by as much as 90 degrees in a completely unloaded condition, or as little as 5 or 10 degrees in a fully loaded condition.

The current, as measured with an ammeter, may only vary a slight amount as the motor changes from a fully loaded condition to a completely unloaded condition. This makes it difficult to detect an unloaded condition by simply monitoring current alone.

To obtain an accurate picture of real power consumption of any inductive device, such as a motor, the formula  $V \times A \times \text{Cos}\theta = W$  is used.

The  $\text{Cos}\theta$  is a multiplication factor derived from the number of degrees of lag between the current and voltage waveforms.

This is called the "power factor" (or "PF"). The power factor is the natural cosine of the degrees of lag:

Degrees of lag	Power Factor	Degrees of lag	Power Factor
0	1.000	50	0.643
5	0.996	55	0.574
10	0.985	60	0.500
15	0.966	65	0.423
20	0.940	70	0.342
25	0.906	75	0.259
30	0.866	80	0.174
35	0.819	85	0.087
40	0.766	90	0.000
45	0.707		

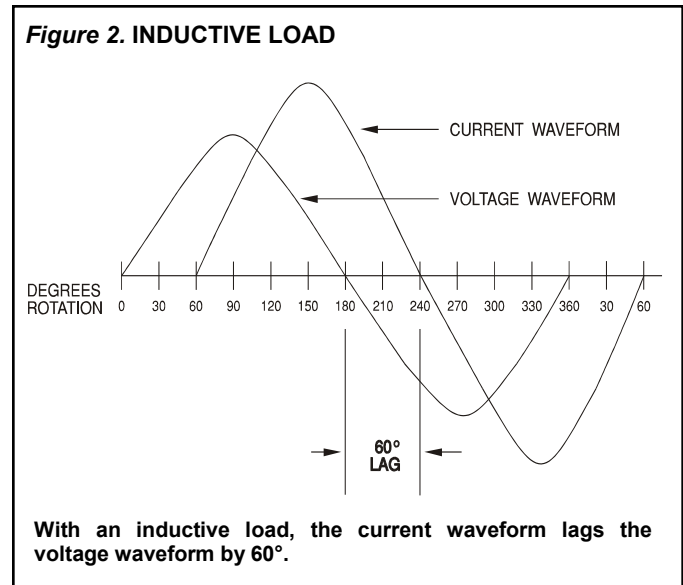
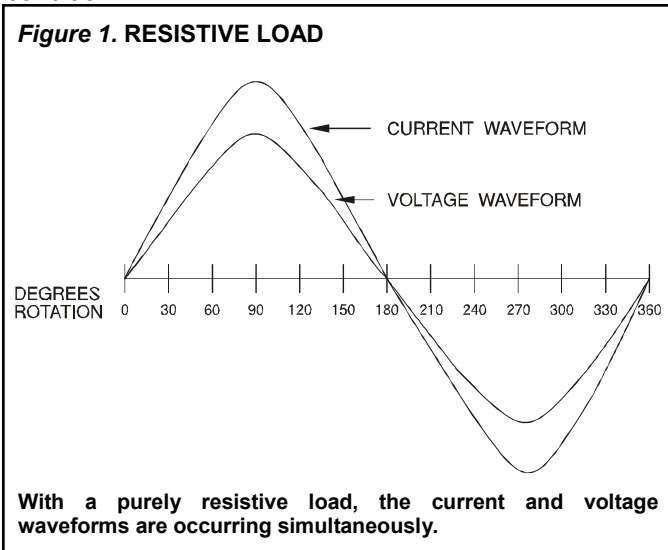

Telephone: Main - (918) 438-1220  
Sales - (800) 862-2875  
Fax: (918) 437-7584

E-mail: sales@time-mark.com  
Internet: http://www.time-mark.com



**TIME MARK**  
CORPORATION

11440 East Pine Street  
Tulsa, Oklahoma 74116

Page 2 of 8 11/2011  
© 2011 TIME MARK CORPORATION

TIME MARK is a division of  AEMT, Inc.

## APPLICATION GUIDE

### Example: TRUE POWER CONSUMED BY AN AC MOTOR

For this example we will use a 3-horsepower, 230 volt, single phase motor.

*Condition 1* represents the motor being used at near full load, while *Condition 2* represents a drop in motor load.

Example:  $(V \times A \times \text{Cos}\phi = \text{Watts})$

Condition 1  
230 volts x 10 amps x 0.985 pf = 2265.5 watts

Condition 2  
230 volts x 9 amps x 0.423 pf = 875.6 watts

Comparing the results of this example, the motor current decreased only 10% with a drop of 61% in the motor load (input power). A drop in motor power cannot be accurately measured by only monitoring the current and voltage.

By monitoring the phase relationship and applying the resultant power factor, an accurate and selective method of sensing changes in true power consumption can be obtained.

The Model 421 Monitor is based on the above principal of detecting the actual power used, and is more sensitive than simple current monitors.

### ADDITIONAL FEATURES

As described previously, the Model 421 would fulfill the basic requirements in most motor protection control systems. However, there are situations which would require the motor to restart automatically after a preset time.

The Model 421 has an **adjustable restart timer** for such applications. This timer has a range of 0.1 to 4 hours. If the restart timer is not needed, turn it off with DIP switch 2.

If restart timing is needed for an underload condition only, the overload restart can be turned off with DIP switch 1.

Resetting the Model 421 is accomplished by cycling the power off and back on, pressing the RESET button, or by using the restart timer (DIP switch 2).

Some applications require a trip delay period before shutting down the motor. The Model 421 has a built-in **trip delay timer**. The timing range is from 0.3 to 180 seconds. The trip delay timer can be turned off with DIP switch 4.

Refer to the chart under *INSTALLATION* (pg 4) for all DIP switch settings.

A 4-20mA output is provided for monitoring power consumption. A 4mA output is equal to 0 watts and a 20mA output is equal to 600 watts at 120 V or 1200 watts at 240 V.

This signal can be sent to a strip chart recorder, a process controller, computer, etc.

### INPUT CURRENT REQUIREMENTS

The CT input of the Model 421 is the isolated winding of a small current transformer within the unit. Ideally, the current range needed should be between 2 and 3.5 amps for a fully loaded motor.

**Polarity** of the wires connected to the CT terminals is **critical** to achieve the correct phase relationship between the current and voltage waveforms as described earlier.

This is simple to determine after the installation is complete (refer to the ADJUSTMENT PROCEDURE, pg 5).

If the full load motor current is 3.5 amps or less, and the motor is a single-phase type, connect one leg of the motor current directly into the Model 421.

Figure 3 shows the **Model 276A** and Figure 4 shows the **Model 276B Current Transformers**, available from Time Mark.

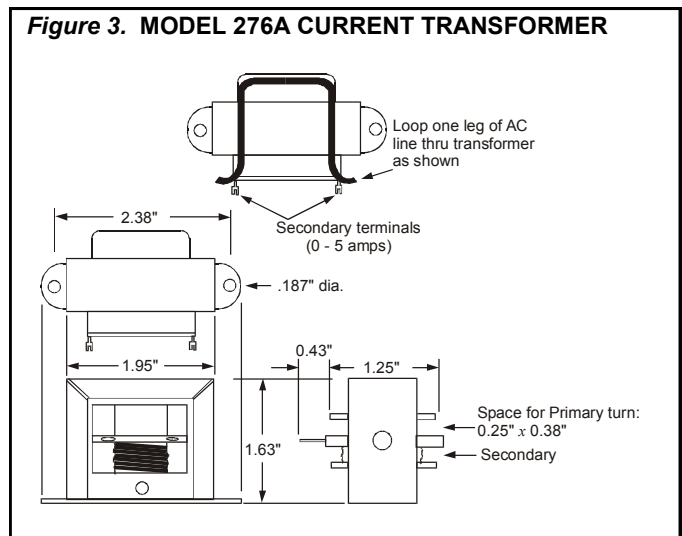

Telephone: Main - (918) 438-1220

Sales - (800) 862-2875

Fax: (918) 437-7584

E-mail: sales@time-mark.com

Internet: http://www.time-mark.com



**TIME MARK**  
CORPORATION

11440 East Pine Street  
Tulsa, Oklahoma 74116

Page 3 of 8 11/2011  
© 2011 TIME MARK CORPORATION

TIME MARK is a division of  AEMT, Inc.

# MODEL 421 Over/Under Motor Load Monitor

## APPLICATION GUIDE

Figure 4. MODEL 276B CURRENT TRANSFORMER

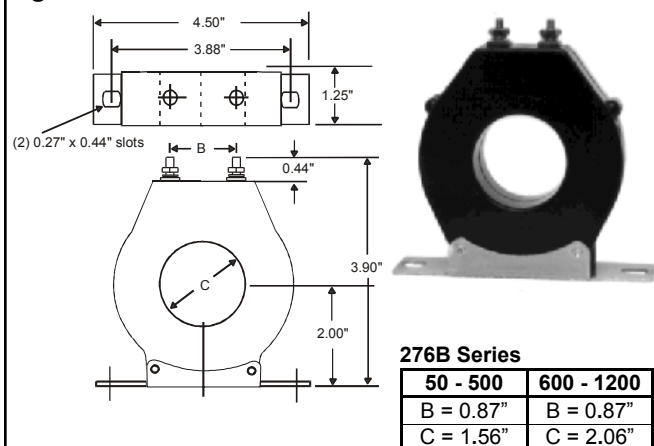

Use the chart below to cross reference your motor horsepower to a Time Mark single-phase or 3-phase current transformer.

Figure 5. CURRENT TRANSFORMER CHART

Motor HP	Time Mark Model Number			
	Single-Phase		3-Phase	
	120VAC	240VAC	240VAC	480VAC
1/4	276A-10	**		
1/3	276A-15	**		
1/2	276A-15	276A-10	*	*
3/4	276A-20	276A-10	*	*
1	276A-25	276A-15	276A-10	*
1 1/2	276A-30	276A-15	276A-10	*
2	276A-35	276A-20	276A-10	*
3	276B-50	276A-25	276A-15	276A-10
5	276B-80	276A-40	276A-25	276A-15
7 1/2	276B-150	276B-60	276A-35	276A-20
10	276B-150	276B-75	276A-40	276A-20
15			276B-60	276A-30
20			276B-80	276A-40
25			276B-100	276B-50
30			276B-150	276B-60
40			276B-150	276B-75
50			276B-200	276B-100
60			276B-250	276B-150
75			276B-300	276B-150
100			276B-400	276B-200
125				276B-250
150				276B-300
200				276B-400
250				276B-500
300				276B-600
350				276B-700
400				276B-750
500				276B-1000

\* Direct connection to Model 276C (see page 8)

\*\* Direct connection to Model 422

## INSTALLATION INSTRUCTIONS

### 3-PHASE INSTALLATION

The basic Model 421 Controller is designed for use with single-phase motors. However, it can easily be used in 3-phase applications by installing the current cancelling transformer, **Model 276C**. The Model 276C (figure 6) monitors two of the three phases, and cancels the effect of the current signal in the third phase, which would otherwise cause a phase shift error in the Model 421.

Figure 6. MODEL 276C

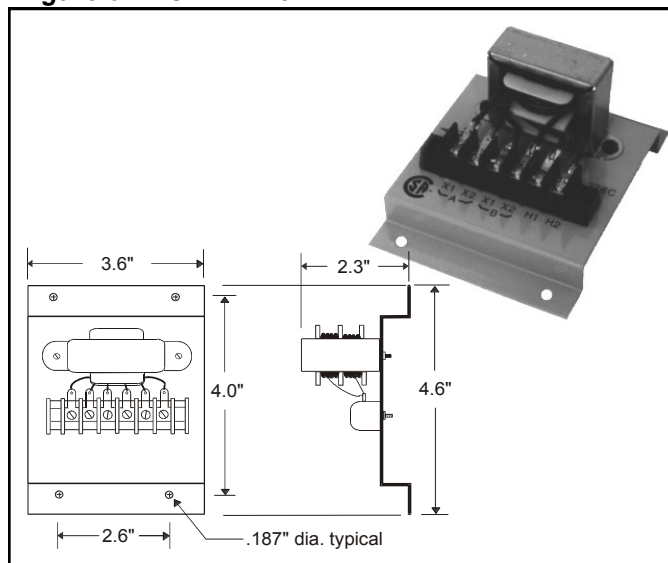

### IMPORTANT NOTE:

*In 3-phase applications, the current inputs must come from the same phases providing the voltage inputs. The applications schematics shown on the last page describe the interconnections.*

### INSTALLATION

Mount the Model 421 in the control panel or in a suitable enclosure. Connect the voltage and current inputs to the appropriate terminals on the Model 421 Monitor.

If the 4-20mA output is used, connect it across a 300Ω resistive load. Set the four MODE switches on the Model 421 according to the chart below. During the initial setup you may wish to disable all time delays.

DIP SW	MODE	ON	OFF
1	Overload Restart	Disabled	Enabled
2	Restart Delay	Enabled	Disabled
3	Reset Button	Enabled	Disabled
4	Trip Delay	Enabled	Disabled

After the system is completely installed, a simple test and adjustment will insure that the polarity and threshold are correct.

Telephone: Main - (918) 438-1220

Sales - (800) 862-2875

Fax: (918) 437-7584

E-mail: sales@time-mark.com

Internet: http://www.time-mark.com



**TIME MARK**  
CORPORATION

11440 East Pine Street  
Tulsa, Oklahoma 74116

Page 4 of 8 11/2011

© 2011 TIME MARK CORPORATION

TIME MARK is a division of AEMT, Inc.

# MODEL 421 Over/Under Motor Load Monitor

READ ALL INSTRUCTIONS BEFORE INSTALLING, OPERATING OR SERVICING THIS DEVICE.  
KEEP THIS DATA SHEET FOR FUTURE REFERENCE.

## GENERAL SAFETY

POTENTIALLY HAZARDOUS VOLTAGES ARE PRESENT AT THE TERMINALS OF THE MODEL 421.  
ALL ELECTRICAL POWER SHOULD BE REMOVED WHEN CONNECTING OR DISCONNECTING WIRING.  
THIS DEVICE SHOULD BE INSTALLED AND SERVICED BY QUALIFIED PERSONNEL.

## INSTALLATION INSTRUCTIONS

### ADJUSTMENT

Connect a temporary jumper across the NO contacts on the Model 421 (this keeps the motor running as the Model 421 trips off and resets).

With the correct voltage applied to the system, the motor should start and run continuously. Make sure the motor is running under its normally loaded condition.

With a clamp-type ammeter, measure the current in one of the wires connected to the CT terminals on the Model 421. A reading between 2 and 3.5 amps should be measured for best results. This current level can be changed by exchanging the CT with a different ratio.

Turn the UNDER adjustment through its entire range and find the spot where the UNDERLOAD LED just illuminates.

Turn the UNDER adjustment until the LED just goes out. If the UNDERLOAD LED is lit all the time, reverse the two wires connected to the CT terminals and re-adjust.

**NOTE: Setting UNDERLOAD to zero does not disable UNDERLOAD monitoring.**

Repeat this procedure for the OVER adjustment. If the OVERLOAD indicator LED stays on all the time, the current input may be incorrect. Check the CTs for proper sizing.

Set the SECONDS adjustment for the appropriate TRIP delay, and HOURS adjustment for the appropriate RESTART delay, as required for the application.

Remove the jumper from the NO contacts; the motor should continue to run. The adjustment is now complete.

### TROUBLESHOOTING

Should the Model 421 Motor Load Monitor fail to operate, check all connections to the device and its control circuits. Insure that the proper voltage and currents have been applied.

Check all fuses. Should the Model 421 operate improperly, check that the CT is properly sized. Check all DIP switch settings. If problems persist, contact the factory for technical assistance.

### OPERATION

When AC voltage is first applied, the output transfers for approximately two seconds, completing the motor control circuit and allowing the motor to come up to speed.

If the power being used is within acceptable limits the contacts remain energized and the motor continues to run. If the power drops or rises outside the limits, the contacts will open.

### WARRANTY

This product is warranted to be free from defects in materials and workmanship for one year. Should this device fail to operate, we will repair it for one year from the date of manufacture. For complete warranty details, see the *Terms and Conditions of Sales* page in the front section of the Time Mark catalog or contact Time Mark at 1-800-862-2875.

Telephone: Main - (918) 438-1220

Sales - (800) 862-2875

Fax: (918) 437-7584

E-mail: sales@time-mark.com

Internet: http://www.time-mark.com



**TIME MARK**  
CORPORATION

11440 East Pine Street  
Tulsa, Oklahoma 74116

Page 5 of 8 11/2011  
© 2011 TIME MARK CORPORATION

TIME MARK is a division of  AEMT, Inc.

## TYPICAL APPLICATIONS

### SINGLE-PHASE, 120V, < 3 HP

#### START-STOP Hookup

REVERSE WIRES TO CT  
IF MOTOR FAILS TO RUN  
FOR MORE THAN THE INITIAL  
2 SECOND PERIOD.

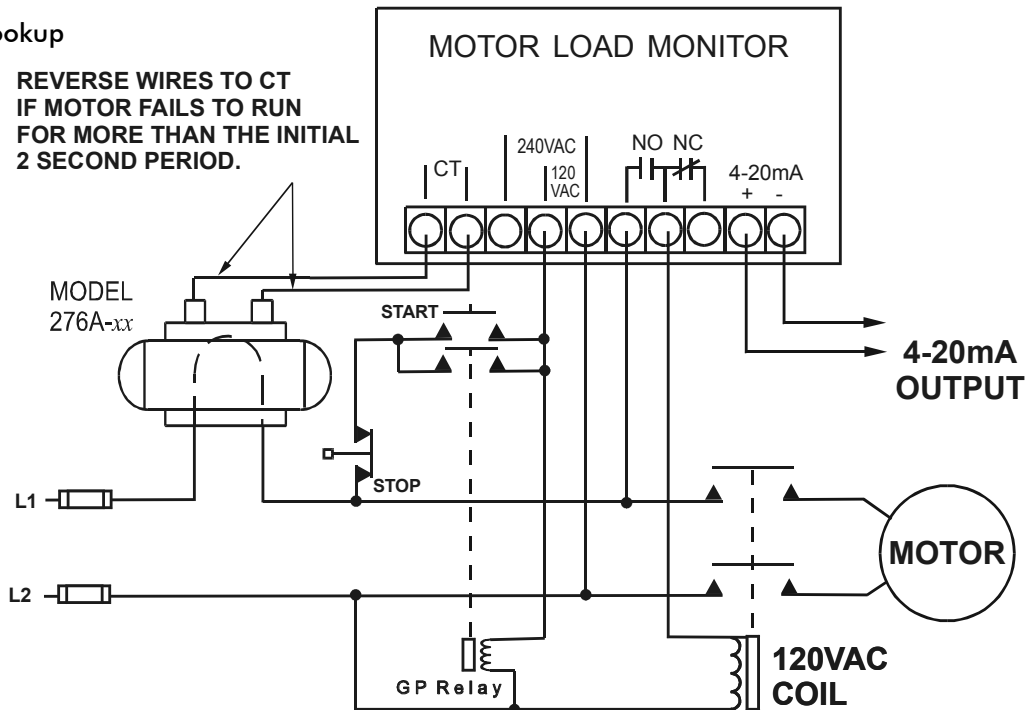

### SINGLE-PHASE, 240V, ≥ 7.5 HP

REVERSE WIRES TO CT  
IF MOTOR FAILS TO RUN  
FOR MORE THAN THE INITIAL  
2 SECOND PERIOD.

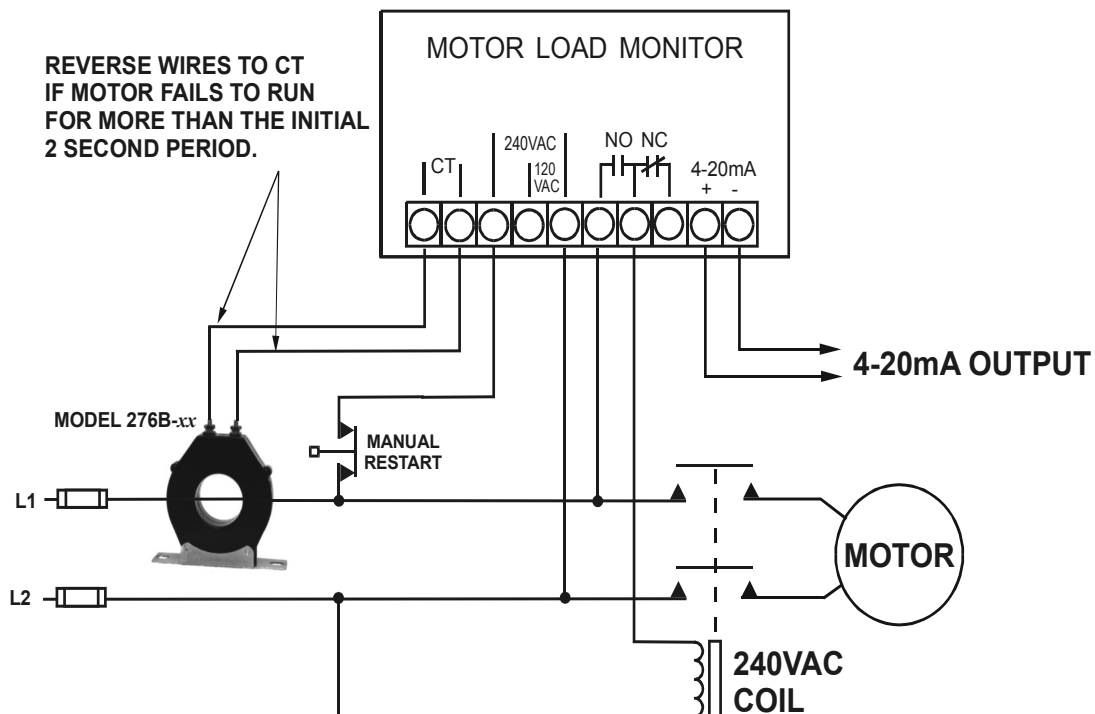

THE INFORMATION PRESENTED IN THIS GUIDE IS CORRECT TO THE BEST OF OUR KNOWLEDGE. HOWEVER, TIME MARK CORPORATION DOES NOT WARRANT THE APPLICATIONS AS OUTLINED NOR MAKE ANY OFFERS THAT THE CIRCUITS ARE FREE FROM PATENT INFRINGEMENT. TIME MARK CORPORATION RESERVES THE RIGHT TO CHANGE OR ALTER SPECIFICATIONS AT ANY TIME.

Telephone: Main - (918) 438-1220

Sales - (800) 862-2875

Fax: (918) 437-7584

E-mail: sales@time-mark.com

Internet: http://www.time-mark.com



**TIME MARK**  
CORPORATION

11440 East Pine Street  
Tulsa, Oklahoma 74116

Page 6 of 8 11/2011

© 2011 TIME MARK CORPORATION

TIME MARK is a division of  AEMT, Inc.

## TYPICAL APPLICATIONS

### SINGLE-PHASE, 240V, 1/2 to 5 HP

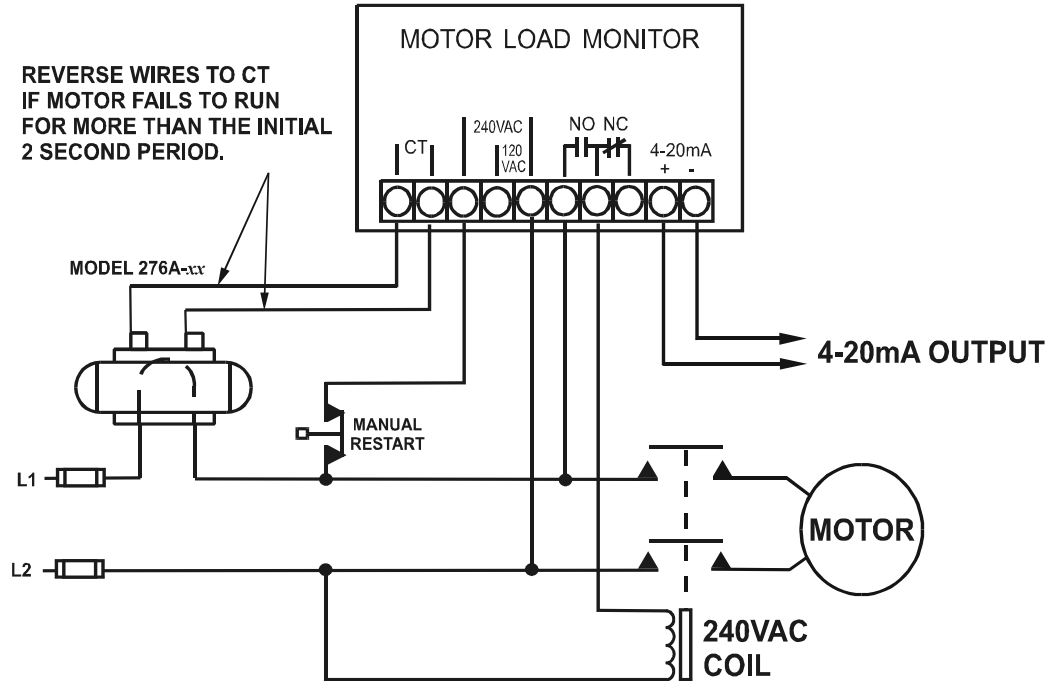

### 3-PHASE, 240V, 1 to 10 HP

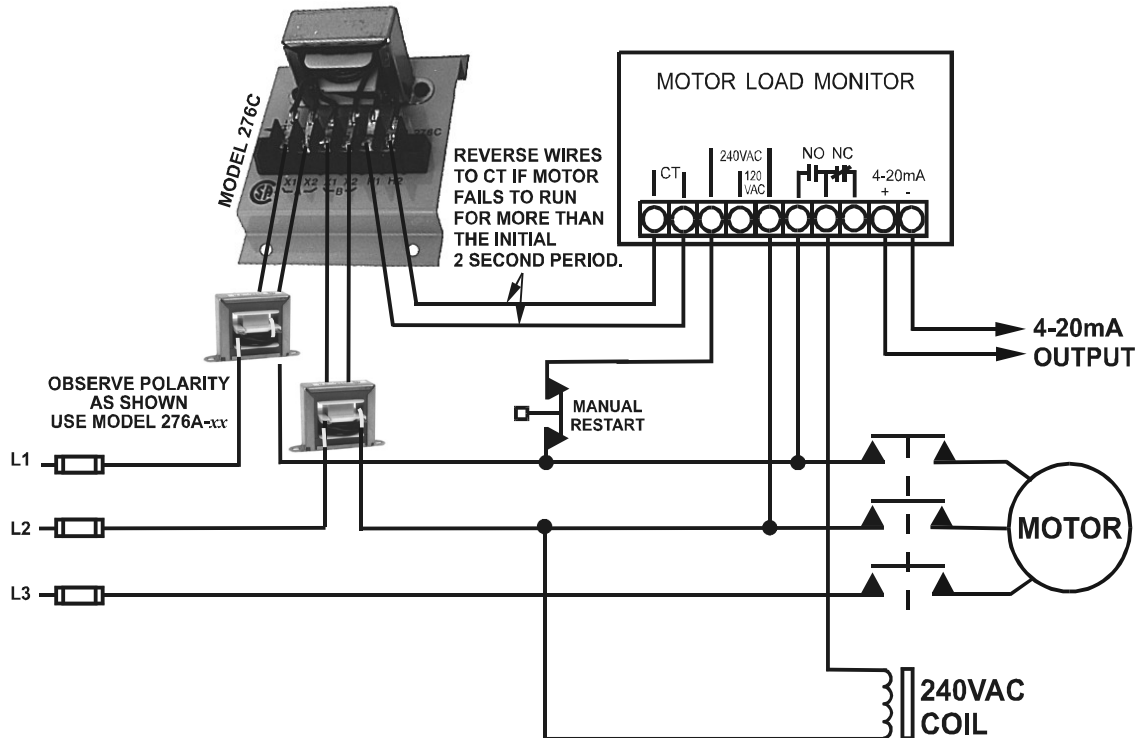

THE INFORMATION PRESENTED IN THIS GUIDE IS CORRECT TO THE BEST OF OUR KNOWLEDGE. HOWEVER, TIME MARK CORPORATION DOES NOT WARRANT THE APPLICATIONS AS OUTLINED NOR MAKE ANY OFFERS THAT THE CIRCUITS ARE FREE FROM PATENT INFRINGEMENT. TIME MARK CORPORATION RESERVES THE RIGHT TO CHANGE OR ALTER SPECIFICATIONS AT ANY TIME.

Telephone: Main - (918) 438-1220

Sales - (800) 862-2875

Fax: (918) 437-7584

E-mail: sales@time-mark.com

Internet: http://www.time-mark.com



**TIME MARK**  
CORPORATION

11440 East Pine Street  
Tulsa, Oklahoma 74116

Page 7 of 8 11/2011  
© 2011 TIME MARK CORPORATION

TIME MARK is a division of  AEMT, Inc.

## TYPICAL APPLICATIONS

### OVER/UNDER LOAD & PHASE LOSS PROTECTION

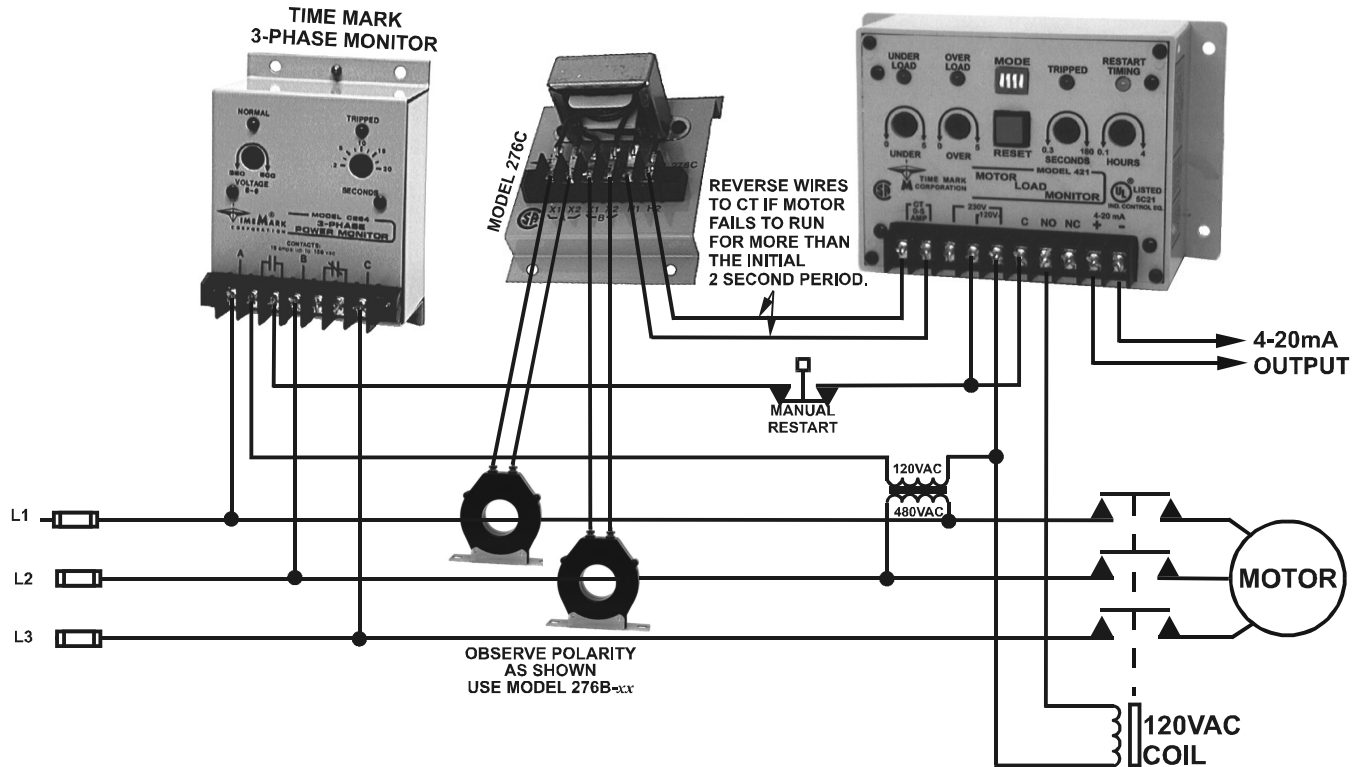

### 3-PHASE, 240V, <1 HP

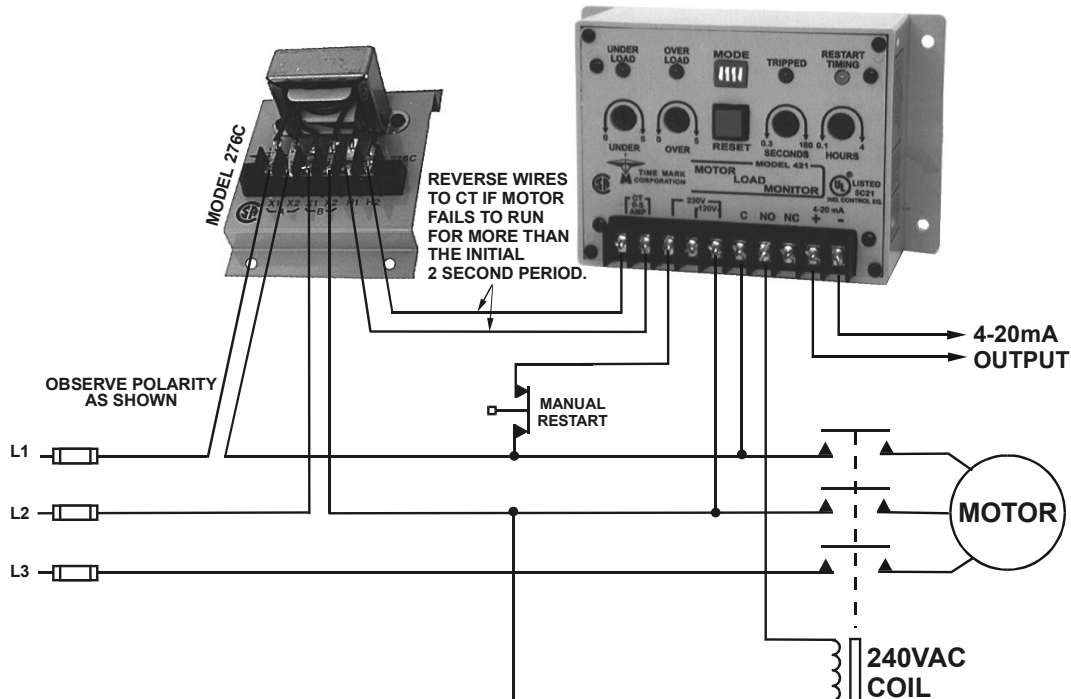

THE INFORMATION PRESENTED IN THIS GUIDE IS CORRECT TO THE BEST OF OUR KNOWLEDGE. HOWEVER, TIME MARK CORPORATION DOES NOT WARRANT THE APPLICATIONS AS OUTLINED NOR MAKE ANY OFFERS THAT THE CIRCUITS ARE FREE FROM PATENT INFRINGEMENT. TIME MARK CORPORATION RESERVES THE RIGHT TO CHANGE OR ALTER SPECIFICATIONS AT ANY TIME.

Telephone: Main - (918) 438-1220

Sales - (800) 862-2875

Fax: (918) 437-7584

E-mail: [sales@time-mark.com](mailto:sales@time-mark.com)

Internet: <http://www.time-mark.com>



**TIME MARK**  
CORPORATION

11440 East Pine Street  
Tulsa, Oklahoma 74116

Page 8 of 8 11/2011

© 2011 TIME MARK CORPORATION

TIME MARK is a division of AEMT, Inc.